

SR NO.	QTY	PART NAME	MATERIAL
01	01	BODY	A479-316
02	01	STEM GLAND	A479-316
03	01	GLAND NUT	A479-316
04	01	CHECK NUT	A479-316
05	01	STEM	A479-316
06	01	STEM TIP	A564-17-4PH
07	01	GASKET	A479-316
08	03	STEM PACKING	GRAPHITE
09	01	STEM PACKING	AISI 316
10	01	HANDLE	AISI 316
11	01	GRUB SCREW	AISI 316
12	01	DUST PROTECTING CAP	PLASTIC LD
13	01	DOWEL PIN	AISI 316

2x ϕ 6 THRU
MOUNTING HOLES

'A'

VIEW:-'AA'

'A'

'B'

'B'

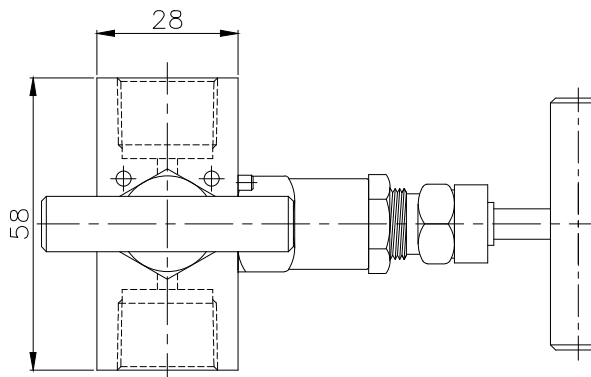
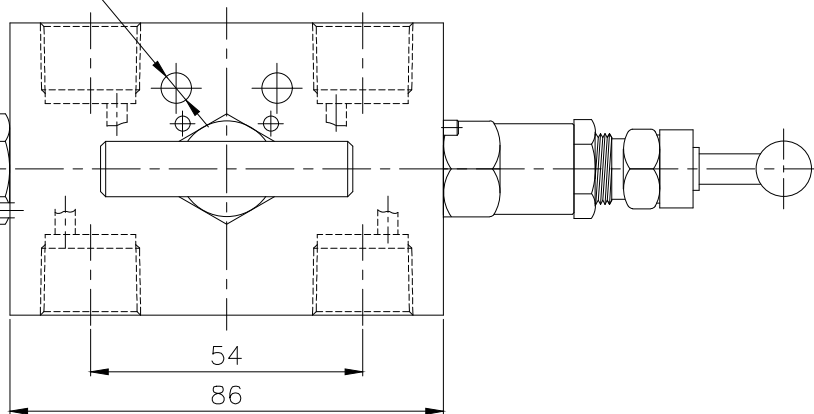

VIEW:-'BB'

Note: All dimensions are subject to change without notice. All dimensions are in millimeters